

**REDODO®**

# PRODUCT MANUAL



# 2000W

## Pure Sine Wave Inverter

12VDC / 110-120VAC

🌐 [www.redodopower.com](http://www.redodopower.com)

✉ [service@redodopower.com](mailto:service@redodopower.com)



# IMPORTANT SAFETY INSTRUCTIONS

Please read the following safety instructions carefully and perform installation and connection operations under the guidance of professionals. This manual contains important safety, installation, and operating instructions for the inverter.

## GENERAL

- ⦿ Read all the instructions and cautions in the manual before the installation.
- ⦿ There are no user-serviceable parts inside this product. **DO NOT** disassemble or attempt to repair the inverter.
- ⦿ **ONLY 12V Battery Banks** are suitable for the inverters.
- ⦿ The product is used with a permanent power source (battery). Input and/or output terminals may still be dangerously energized, even when the product is switched off. **ALWAYS** make sure the inverter is in the **OFF position** and **disconnect all AC and DC connections** before carrying out maintenance or servicing the product.
- ⦿ Consult the battery manufacturer's information to ensure that the product is intended for use with the battery. Carefully check the specific requirements of the batteries used in the system and always follow the battery manufacturer's safety instructions.
- ⦿ Never use the product where there is a risk of gas or dust explosions.

## BATTERY

- ⦿ It is recommended that the DC and AC input cables be fused and fitted with circuit breakers.
- ⦿ Before applying power, ensure that the available power source matches the product configuration settings described in the manual.
- ⦿ The product should be installed in a well-ventilated, cool, and dry environment. Make sure there is adequate ventilation space around the product and check that the vents are not blocked.
- ⦿ After installation, check whether all wiring connections are tight and reliable to avoid the danger of heat accumulation due to loose connections.

If you have any questions or need any help, please feel free to contact us (and leave your contact phone number) at [service@redodopower.com](mailto:service@redodopower.com), we will offer phone or email support in 12hrs.



# PRODUCT OVERVIEW

## REDODO 2000W PURE SINE WAVE INVERTER

Continuous Power	2000W
Input Voltage	12V DC
Max. Alternator Input Power	110-120V AC

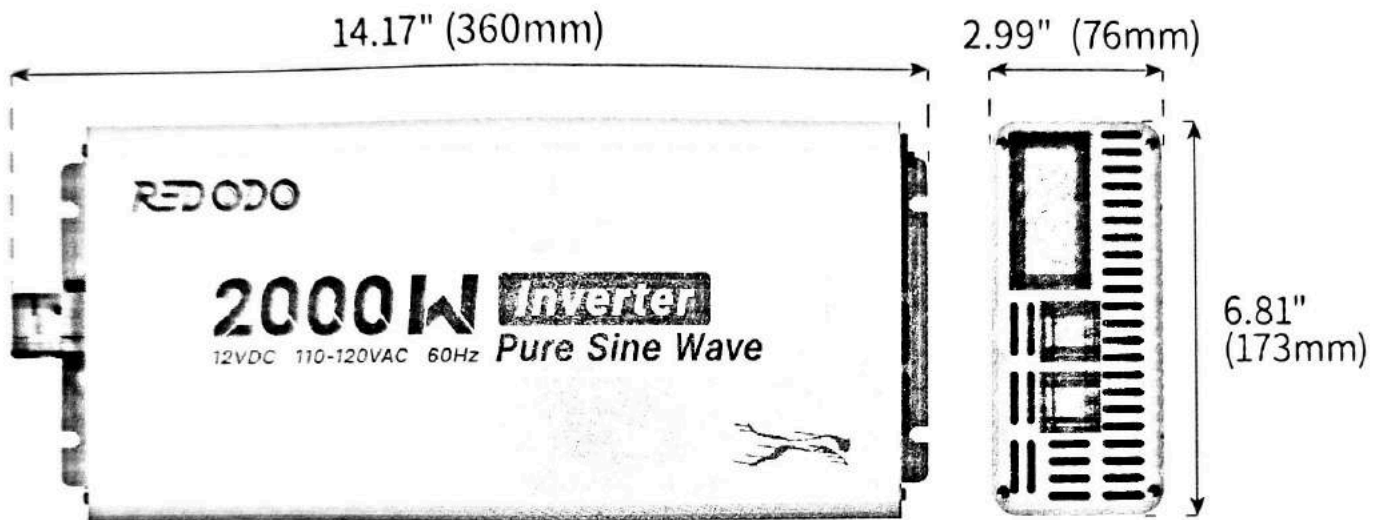

Fixed Mounting  
(Mounting screws included)  
 $\Phi 15/64$ " (6mm)

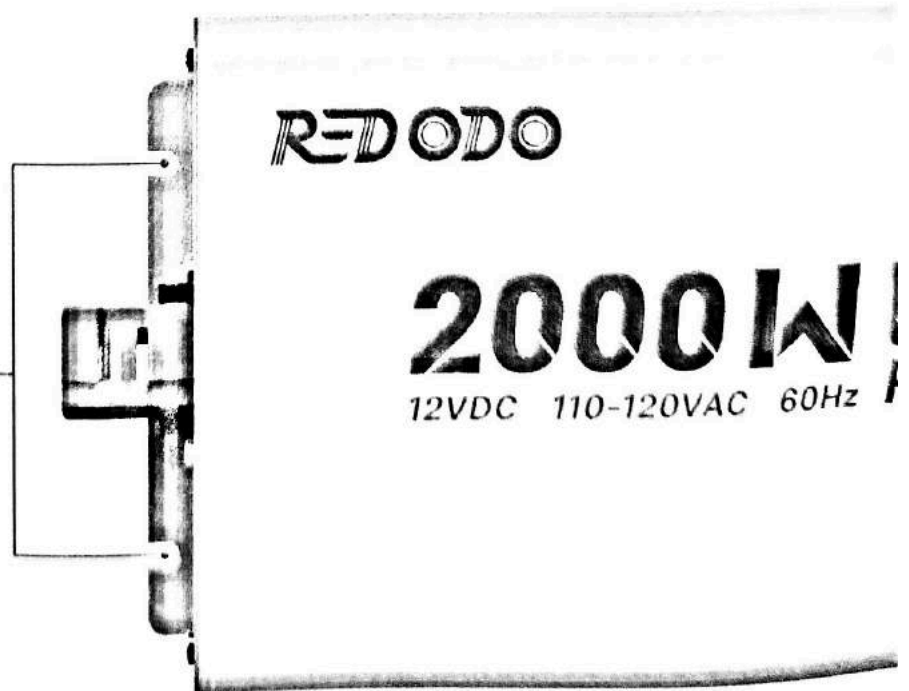



# ADDITIONAL COMPONENTS

Additional components are included in the package.

## 2x(2\*8AWG) 1.8FT BATTERY TO INVERTER CABLES

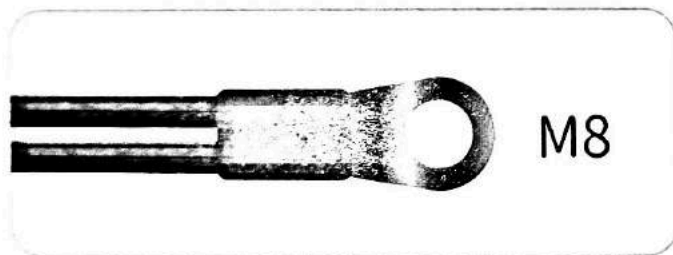
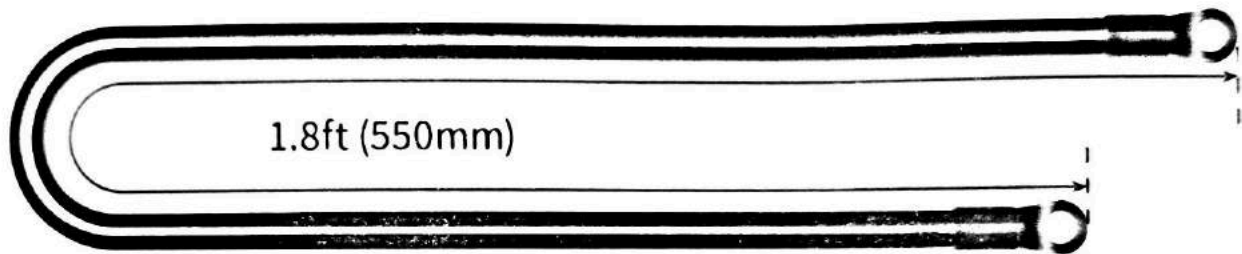
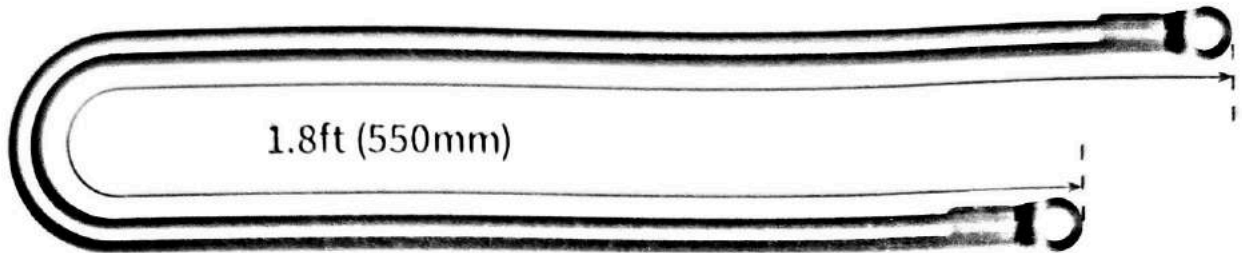

## MOUNTING SCREWS\*4 / PLASTIC ANCHORS\*4

Mounting screws and plastic anchors for fixed mounting on wood wall or drywall are provided..

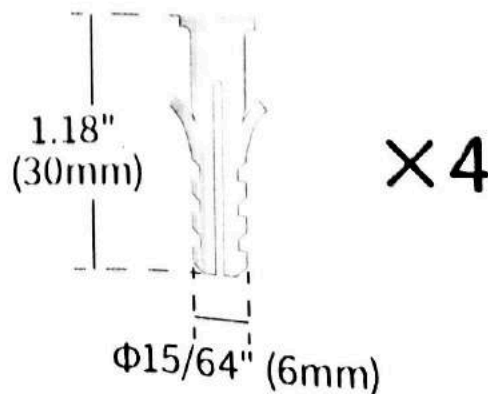
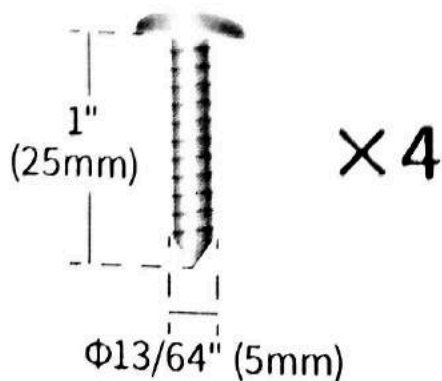

# CONTENTS

## **INVERTER PARTS**

page **01**

Identification of Parts

01

LCD Indicators

02

## **INSTALLATION**

page **03**

Choosing Location

03

Sizing a Battery Bank

04

Connecting to a Battery Bank

05

Connecting to Devices

07

## **SPECIFICATIONS**

page **08**

## **TROUBLESHOOTING**

page **09**



# INVERTER PARTS

## IDENTIFICATION OF PARTS

### ≡ AC Side

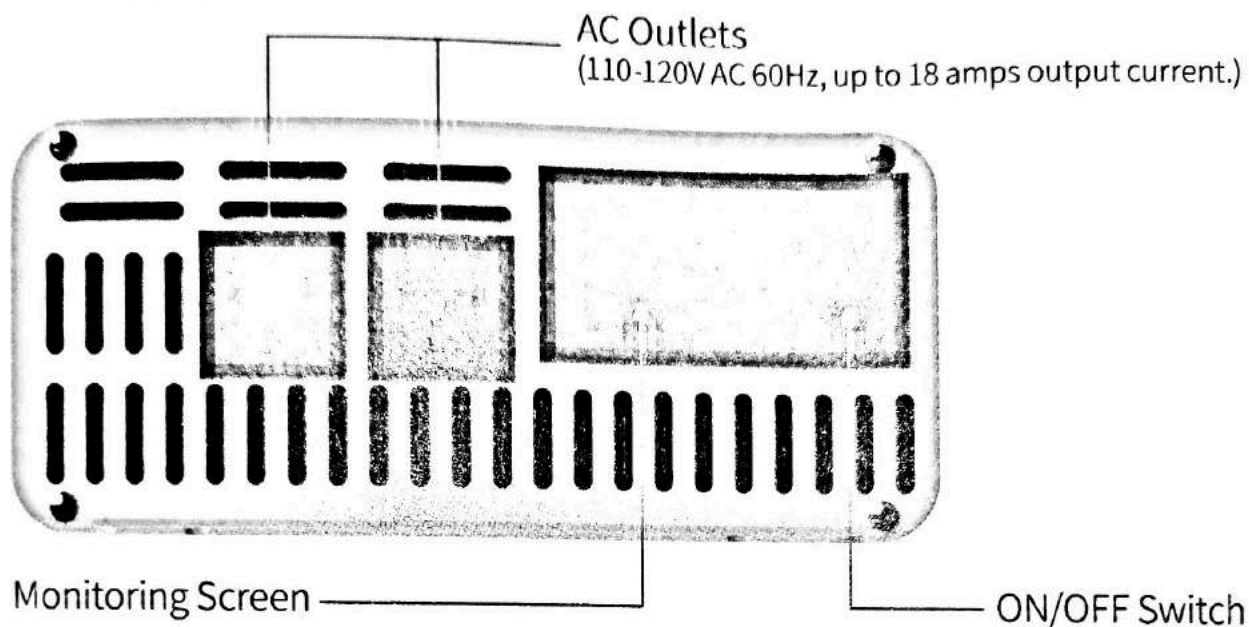

### ≡ DC Side

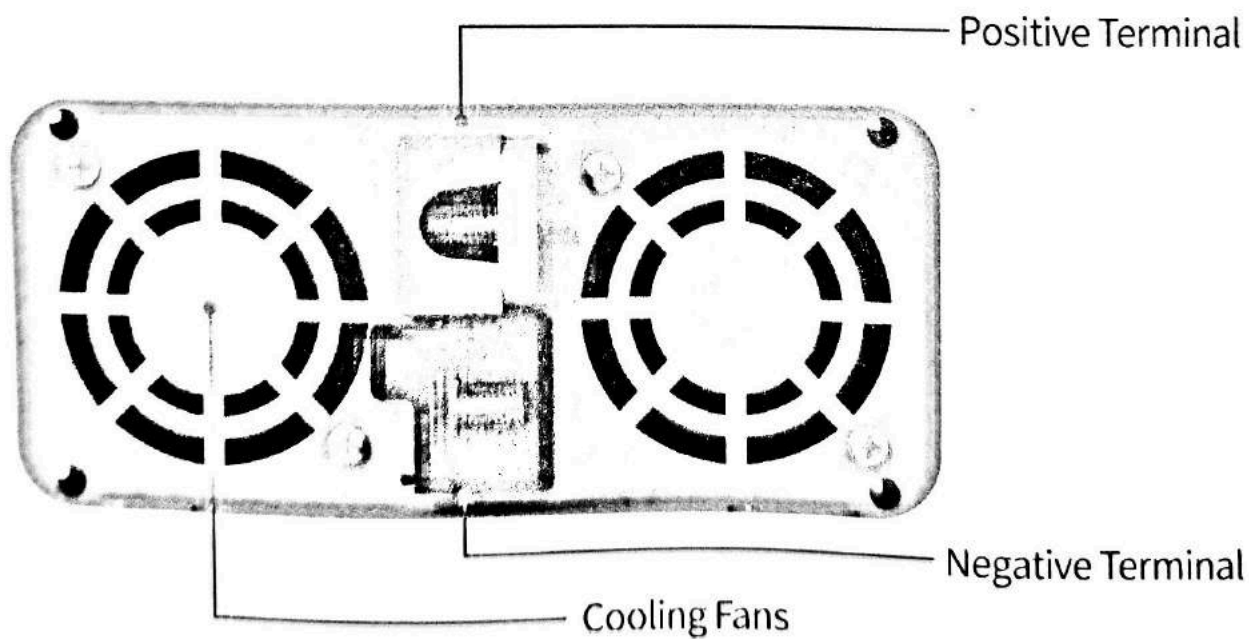

# LCD INDICATORS

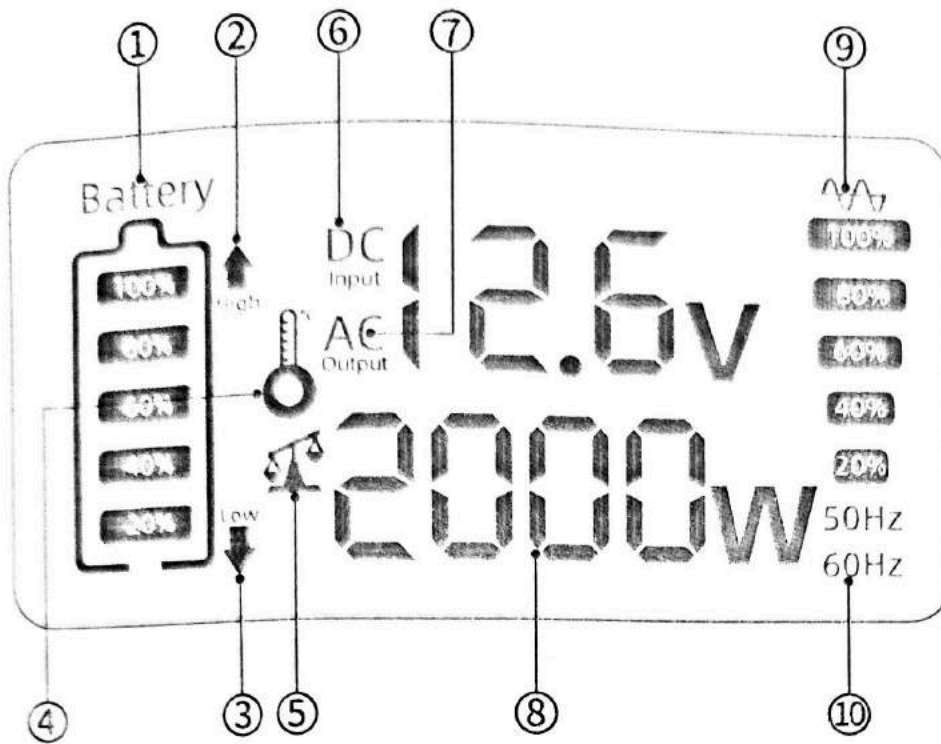

- ① Remaining Capacity of Battery Bank
- ② Over Voltage Protection
- ③ Low Voltage Protection
- ④ High Temperature Protection
- ⑤ Overload Protection
- ⑥ DC Input Voltage
- ⑦ AC Output Voltage
- ⑧ Output Power
- ⑨ Load Ratio<sup>①</sup>
- ⑩ Frequency

① Load Ratio=Output Power(W)/Inverter Continuous Power(W). For example, if the load is currently running at 400W, the load ratio is 400W/2000W=20%.



# INSTALLATION

- ≡ The product should be installed by a qualified electrician.
- ≡ Make sure the inverter is in the off position before connecting anything.

## CHOOSING LOCATION

Make sure the installation complies with the following guidelines.

- ≡ **In a well-ventilated, cool, and dry environment**

The product must be installed in an area protected from direct sunlight, high temperatures, and water. Make sure there is sufficient room for wiring and ventilation clearance from the DC and AC sides of the product. Clearance should be at least 10 inches (25cm).

- ≡ **As close to the battery as possible.**

Keep the product and battery as close as possible to minimize cable voltage loss and choose a proper wire size to connect the product and battery.

- ≡ **Securely placed or mounted.**

This product could be stand-alone, or wall-mounted both horizontally and vertically. Horizontal mounting is preferred for optimum cooling.

Never place the inverter vertically on a vertical surface since this could block the fan opening, which are essential for the inverter's cooling.

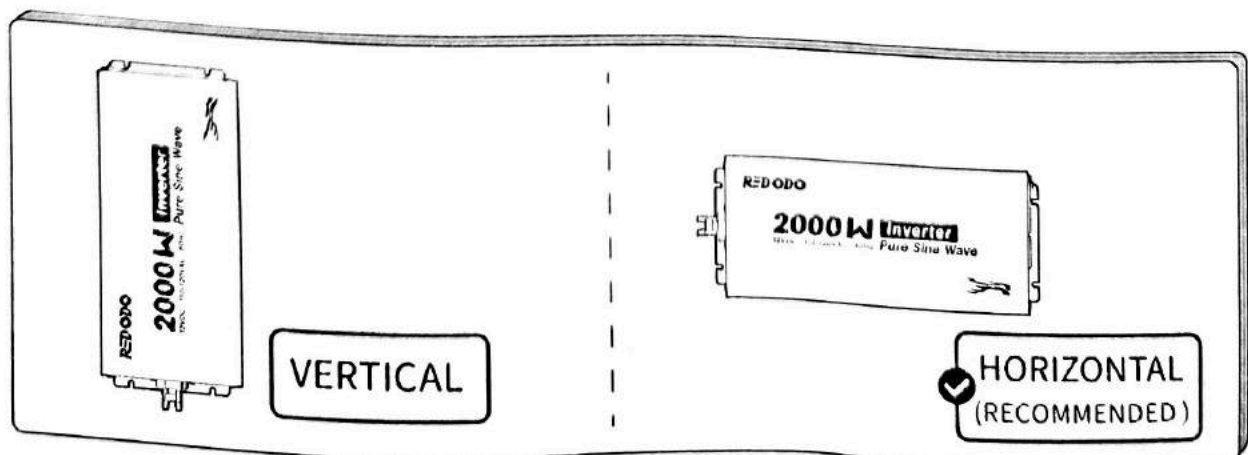



## SIZING A BATTERY BANK

The selection of the battery bank can be calculated to reach a suitable conclusion.

Data to be Confirmed	The rated output power(W) of the load <sup>①</sup> to be run.
	Expected runtime time(hrs) of the load.
	The nominal voltage of the selected battery type and voltage.
Reference Calculation Formula	$\text{Energy(Wh)} = \text{Load Power(W)} * \text{Runtime(Hrs)} / \text{Inverter Efficiency}^{\text{②}}$ $\text{Capacity(Ah)} = \text{Energy(Wh)} / \text{Battery Nominal Voltage(V)}$

- ① The rated output power(W) of the load should be less than the continuous power supported by the inverter (2000W for this product).
- ② Inverter Efficiency=Inverter Output Power/Inverter Input Power, 85% is the usual conversion efficiency of the product under normal conditions.

For LiTime lithium batteries and this inverter, the battery bank will be 12 volts direct current (12 VDC) with 12.8V nominal voltage.

### Example

● 1000W Load(s)

● 3Hrs runtime/day

● 12.8V lithium battery

$$1000W * 3Hrs / 85\% \approx 3529Wh$$

$$3529Wh / 12.8V \approx 276Ah$$

To use the 1000W Load(s) for 3 hours per day, at least a 12V (12.8V) 276Ah lithium battery should be selected on an everyday battery fully charged basis.

If there are different requirements for the time to fully charge the battery, the calculation method will be more complicated. Please feel free to contact us at [service@redodopower.com](mailto:service@redodopower.com) for a free recommendation of a customized solution.

## CONNECTING TO A BATTERY BANK

- ≡ This product is **ONLY** suitable for a **12V battery bank**. Failure to comply with the proper DC voltage will cause irreversible damage to the product.
- ≡ Avoid direct contact between the terminals of the positive and negative wires connected to the battery, and do not reverse the positive and negative connections. Damage to the Redodo inverter and battery due to reverse polarity is **NOT** covered by warranty.

**Step 1** Connect the included wires to the battery terminals.

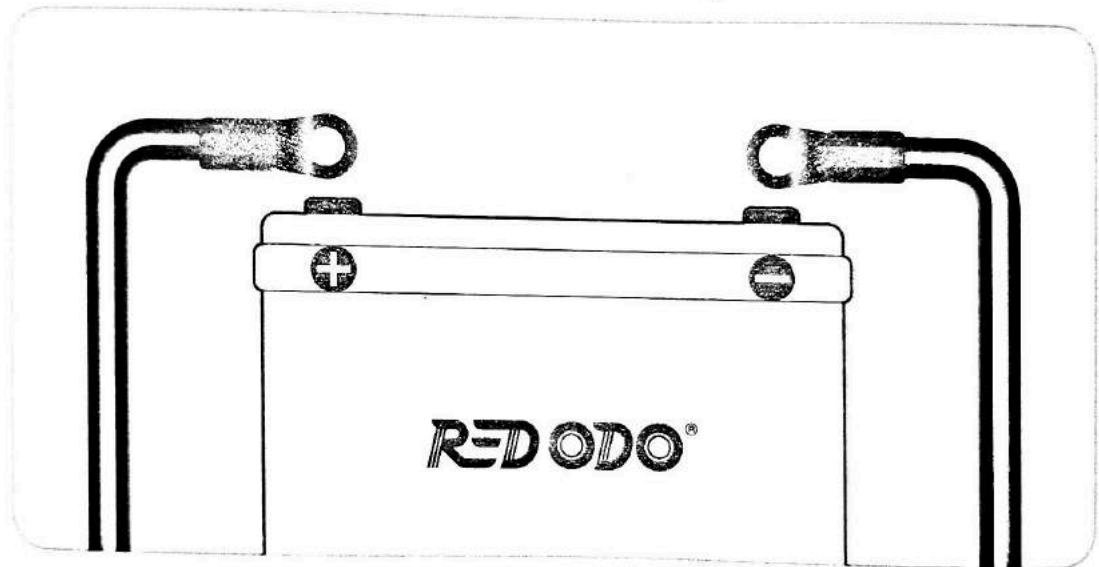

**Step 2** Make sure the inverter is in the OFF status.

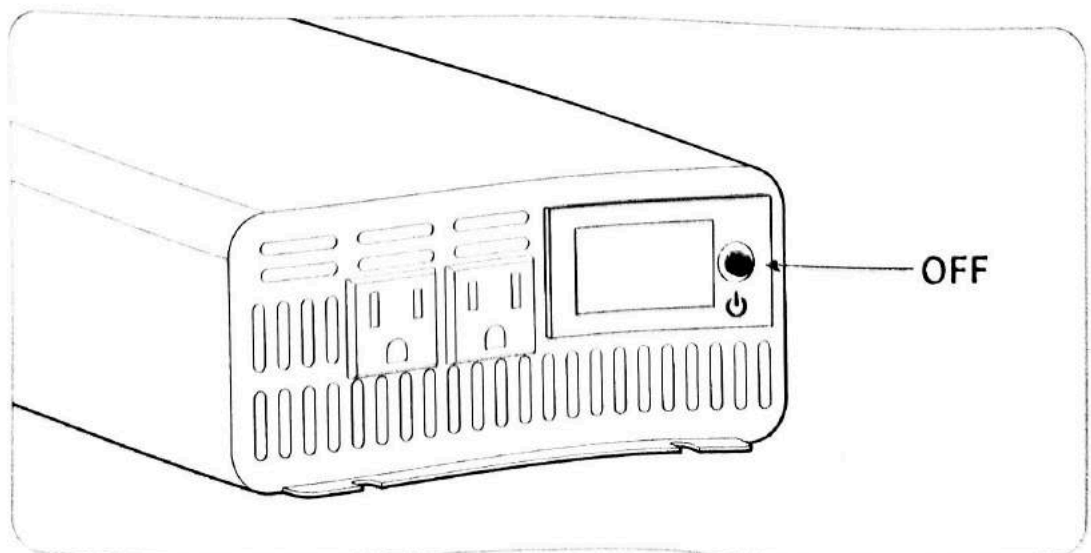

Step  
**3**

Remove the insulating caps on the terminals, and unscrew the metal hexagon nuts with flange from the bolts.

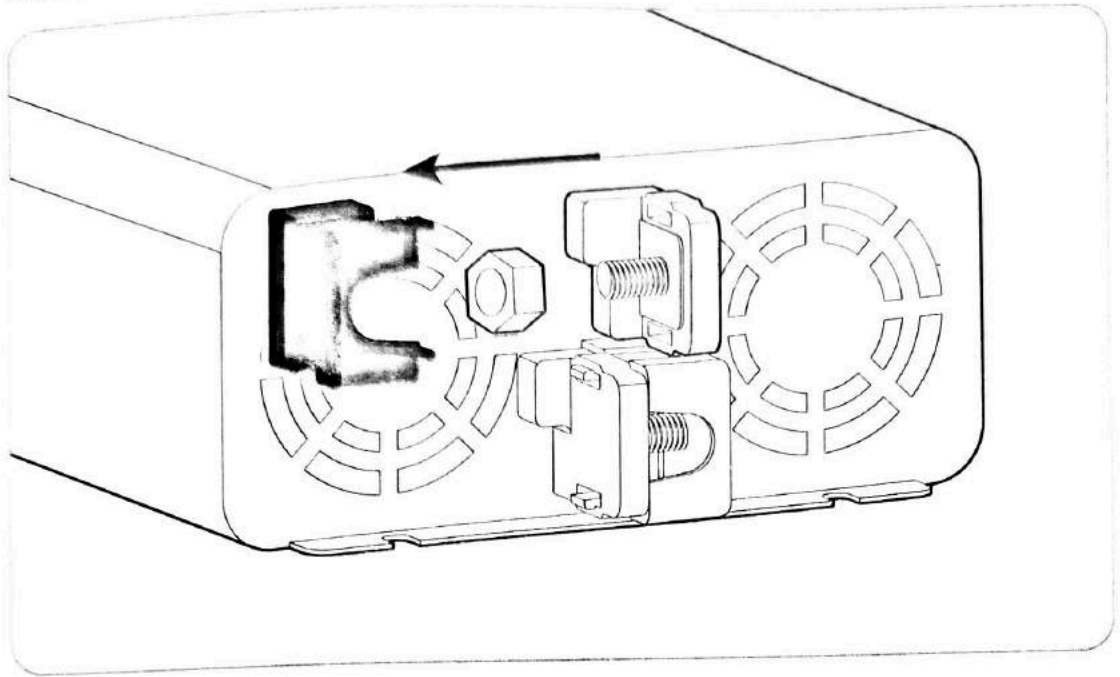

Step  
**4**

Attach the wire lugs and metal hexagon nuts with flange to the bolts in the following sequence: Wire Lug → Metal Hexagon Nut with Flange.

Use a torque wrench to tighten the nuts to the bolts under the 12 N·m to 14 N·m setting to connect the wires to the inverter,

⊕ to ⊕    ⊖ to ⊖

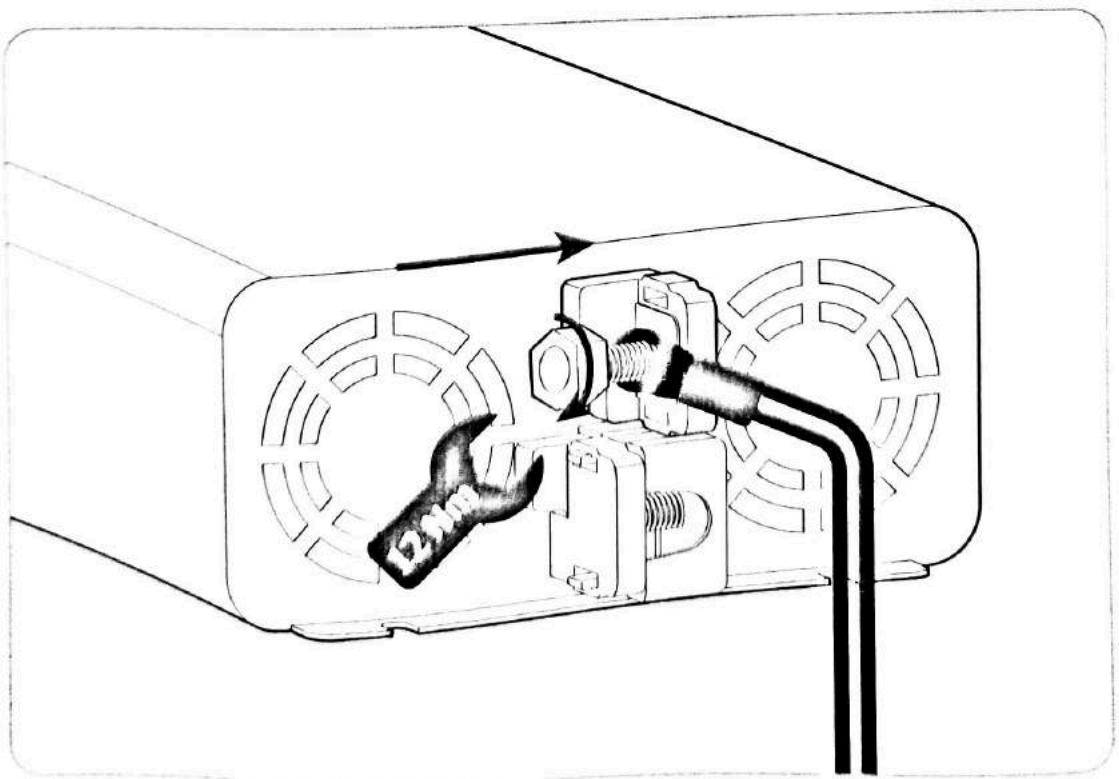

Step  
**5**

Put on the insulating caps.

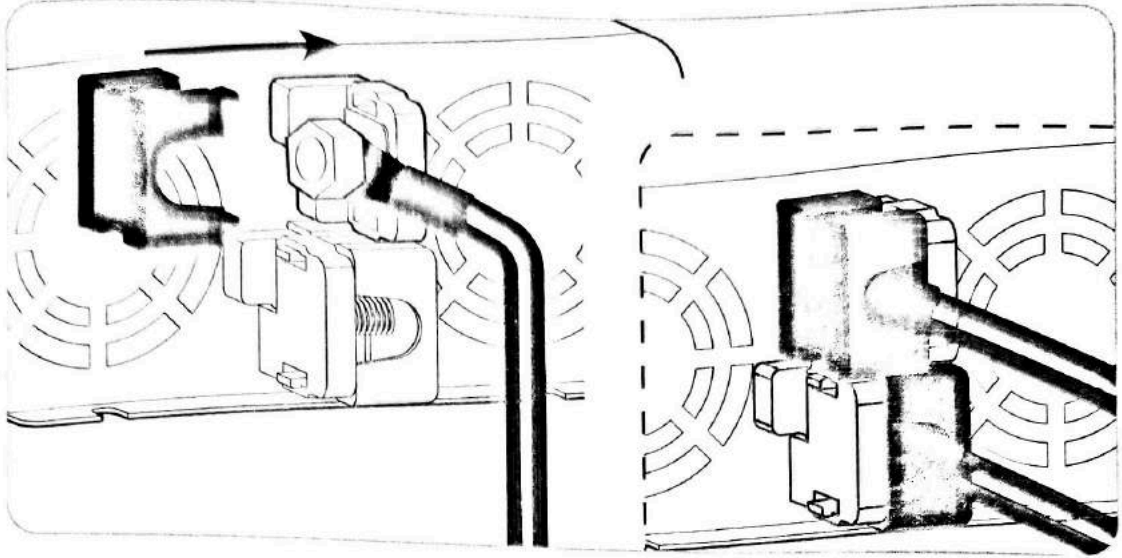

Step  
**6**

Turn ON the inverter power, the monitoring screen will light up assuming proper battery connection, and the inverter is now ready for use.

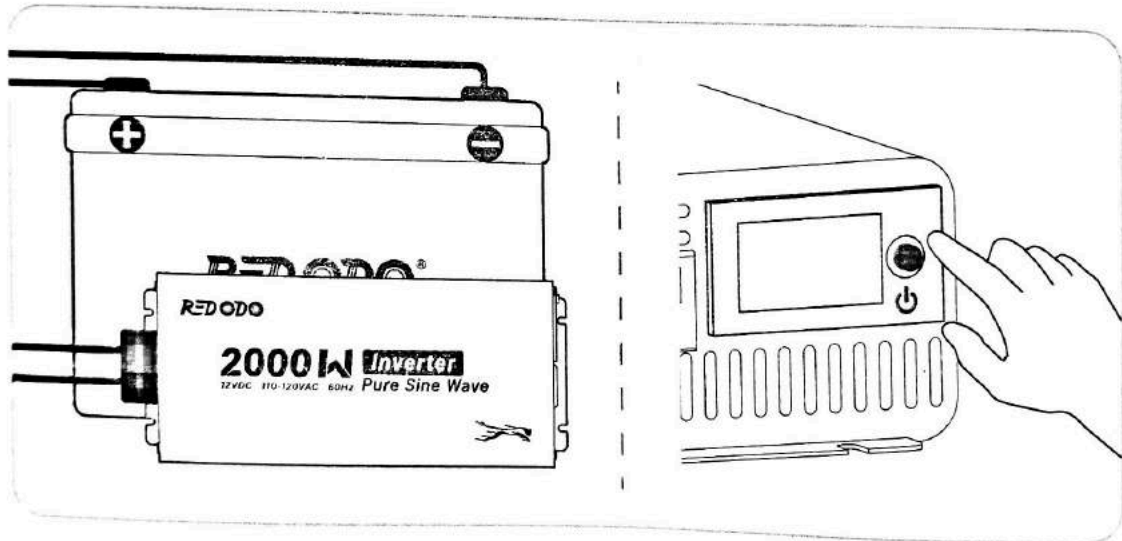

## CONNECTING TO DEVICES

- ≡ Make sure the inverter is in the OFF position before connecting loads (electronic devices) to the AC outlets.
- ≡ Avoid switching on the inverter with the load already turned on. This may trigger an overload since some electronic devices have an initial high power surge to start.
- ≡ Be sure to turn off all loads first before switching off the inverter. Even if the inverter is turned off, the capacitors will still have a charge, so the DC and AC terminals must be disconnected if altering the circuitry.







# SPECIFICATIONS

Parameter	Value
Continuous Power	2000W
Peak of Surge Power	4000W
Input Voltage Range (VDC)	10.0V-15.5V DC
Output Voltage	110V AC $\pm$ 10%
Frequency	60Hz
Efficiency	90%
No Load Power Consumption	<9W
Battery Low Shutdown	10.0 $\pm$ 0.3V DC
Over Voltage Shutdown	15.5 $\pm$ 0.3V DC
Operating Temperature	-4°F to 122°F / -20°C to 50°C
Dimensions (L*W*H)	14.17 * 6.81 * 2.99 inch 360 * 173 * 76 mm
Weight	8.82 lbs / 4 kg



# TROUBLESHOOTING

Icon	Description	Solutions
 High	The DC input (battery) voltage is too high.	Ensure that the battery voltage is lower than about 15.5V.
Low 	The DC input (battery) voltage is too low.	Charge the battery or check the battery connections. Ensure that the battery voltage is higher than about 10V.
	The inverter temperature is too high.	<ul style="list-style-type: none"><li>○ Cool down the product to room temperature to resume power.</li><li>○ Place the inverter in a cool and well-ventilated room, or reduce the load power on the inverter.</li></ul>
	The load power on the inverter is higher than the rated power.	Reduce the load power.

If the problem cannot be resolved or you need any help, please contact us at [service@redodopower.com](mailto:service@redodopower.com).



**PROVIDER**

Shenzhen Maicheng Technology Innovation Co., Ltd.

**MANUFACTURER CONTACT**

[service@redodopower.com](mailto:service@redodopower.com)

[technicalsupport@redodopower.com](mailto:technicalsupport@redodopower.com)